



Bobcat®

331



EXCAVATORS

Specifications

Weights

331

| | |
|---------------------------------------|---------|
| Operating weight with ROPS canopy | 3259 kg |
| Additional weight for cab with heater | 119 kg |
| Additional weight for cab with HVAC | 141 kg |
| Additional weight for steel tracks | 72 kg |

Engine

| | |
|--------------------------------------|------------------------------|
| Make / model | Kubota / V2203-M-DI-E2B-BC-4 |
| Fuel / Cooling | Diesel / Liquid |
| Maximum power at 2400 RPM (ISO 9249) | 30.3 kW |
| Torque at 1500 RPM (ISO 9249) | 140.3 Nm |
| Number of cylinders | 4 |
| Displacement | 2.2 l |
| Bore / Stroke | 87.0 mm / 92.4 mm |
| Alternator | 12 V — 90 A |
| Starter | 12 V — 2.0 kW |

Controls

| | |
|------------|--|
| Steering | Direction and speed controlled by two hand levers or foot pedals |
| Hydraulics | Two joysticks control boom, bucket, dipperstick and upper structure slew |

Hydraulic System

| | |
|----------------|--|
| Pump type | Dual-outlet variable displacement piston pumps |
| Pump capacity | 2 x 38.4 l/min at 2400 RPM |
| Auxiliary flow | 62.1 l/min |
| Control valve | Ten-spool closed centre parallel series |

Performance

| | |
|---|----------|
| Digging force, dipperstick | 17099 N |
| Digging force, bucket | 30451 N |
| Drawbar pull | 34838 N |
| Ground pressure with canopy and rubber tracks | 29.1 kPa |
| Ground pressure with cab and rubber tracks | 30.5 kPa |
| Travel speed, low range | 2.7 km/h |
| Travel speed, high range | 5.2 km/h |
| Maximum digging depth | 3102 mm |

Slew System

| | |
|-------------------|--|
| Boom swing, left | 90° |
| Boom swing, right | 50° |
| Slew circle | Single row shear-type ball bearings with internal gear |
| Slew drive | Orbit motor |
| Slew rate | 9.2 RPM |

Traction

| | |
|----------------------------------|--------|
| Track width, rubber, standard | 320 mm |
| Number of track rollers per side | 4 |
| Gradeability | 30° |

Brakes

| | |
|---------------|--------------------------------------|
| ATravel brake | Hydraulic lock on motor |
| Slew brake | Hydraulic lock on motor and pin lock |

Fluid Capacities

| | |
|------------------------------------|--------|
| Cooling system | 17.0 l |
| Engine lubrication plus oil filter | 7.1 l |
| Fuel reservoir | 53.3 l |
| Hydraulic reservoir | 29.5 l |
| Hydraulic system | 44.0 l |

Working Range

All dimensions in mm.

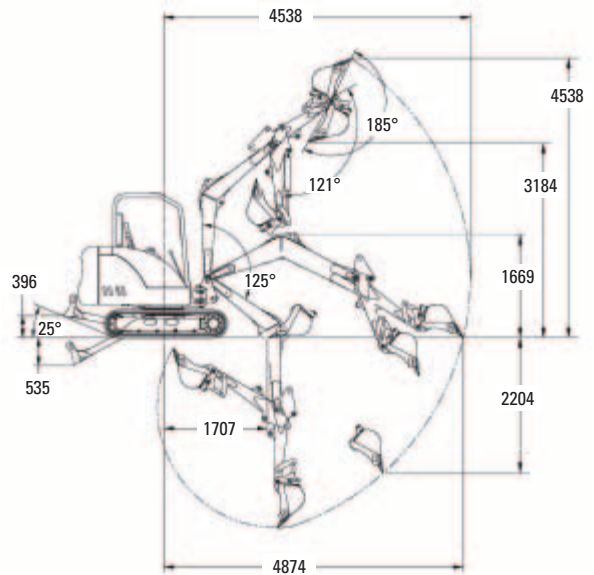

Dimensions

All dimensions in mm.

